

INDEX	PAGE
<b>INSTALLATION IMPERATIVES</b>	<b>2</b>
<b>A. PRODUCT / ACCESSORIES / TOOLS REQUIRED</b>	<b>3</b>
A1. Product Description	3
A2. Recommended Tools & Accessories	3 - 4
<b>B. GENERAL COMMENTS APPLICABLE TO INTERNAL &amp; EXTERNAL APPLICATIONS</b>	<b>5</b>
B1. Scope	5
B2. Storage	5
B3. Safe Working Practices & Handling	5
B4. Design	5
B5. Fasteners	5
B6. Framing	5
B7. Board Layout and Side Up	5 - 6
B8. Finishes	6
B9. Maintenance	7
<b>C. INTERNAL &amp; EXTERNAL INSTALLATION</b>	<b>7</b>
C1. General Notes	7
C2. Installation of Boards	7
C3. Installation of Butt Joints	8
C4. Control Joints – Tiled areas only	8
C5. External Installation – Further Considerations	8
<b>D. WATERPROOFING</b>	<b>9</b>
D1. Waterproofing Systems	9
D2. Waterproof System 1: Liquid Membrane Method	9
D3. Waterproof System 2: Slip Panel & Reinforced Mortar Bed	9
<b>E. PRODUCT INFORMATION, WARRANTY &amp; DISCLAIMER</b>	<b>9</b>
E1. Product Information	9
E2. Product Warranty	9
E3. Disclaimer	9

## INSTALLATION IMPERATIVES

The following are "must do's" when installing OxyMag floor boards:

NO.	INSTALLATION IMPERATIVE	REFERENCE	PG.
1	<b>OxyMag floor boards must be stored, installed, finished and maintained as per this guide. Otherwise OxyMag's product warranty will be invalidated.</b>	A1.a.ix.	3
2	<b>Prior to installation, OxyMag boards must be stored flat, dry, indoors, undercover and above ground.</b>	B2.a.	5
3	<b>Both the 16mm and 19mm boards have maximum joist centres of 450mm and 22mm boards have maximum joist centres of 600mm</b>	A1.a.iv. B4.3. Table 1 C2. Fig.5	3, 5, 7
4	<b>Boards must be laid with the rough (sanded) side facing up.</b>	A1. - Fig.1 C2.a.	3, 7
5	<b>Approved construction adhesives / joint sealants must be used – See approved brands</b>	A2.g.	4
6	<b>A continuous 6mm bead of approved construction adhesive must be applied to joists.</b>	C2.d. - Step 1, Fig.5	7
7	<b>A continuous bead of approved joint sealant must be used to fill the groove of one board prior to an adjacent board's tongue being slotted into the groove.</b>	C2.d. - Step 3, Fig.6	7
8	<b>Fasteners can't be more than 200mm apart. Thus, at least 4 fasteners must be used along each joist for each 600mm wide board.</b>	C2.d. – Table on Fig.5	7
9	<b>The OxyMag boards must at all times be protected from rain, standing water, and uncontrolled moisture exposure during installation and prior to final finishing. It is the builder's / installer's responsibility to provide temporary weather protection (eg: builder plastic, temporary roofing or equivalent) immediately after installation and until the boards are covered with an appropriate finish.</b>	A2.h. B9.	4, 7
10	<b>Should a non-approved waterproofing brand/s be used, the OxyMag product warranty will be invalidated.</b>	A2.i.	4
111	<b>The OxyMag boards must be waterproofed &amp; tiled or covered with an appropriate finish within 90 days after installation. Important: A primer, epoxy, non-slip and/or any similar coating does not constitute an appropriate finish.</b>	A2.h. B8.1. B9./C2.	4, 6, 7

The above points do not diminish the validity of all other points in this installation guide which must also be followed.

## A. PRODUCT / ACCESSORIES / TOOLS REQUIRED

### A1. PRODUCT DESCRIPTION

- a. OxyMag floor boards are:
- Independently tested and certified to meet NCC/BCA Deemed-to Satisfy structural requirements for floor loadings to AS/NZS 1170.1 Table 3.1. See OxyMag Design and Load Tables for more information
  - High strength, yet light-weight, reinforced cement composite floor boards for internal and external residential applications. The 19mm and 22mm boards (not 16mm boards) can be used for commercial applications.
  - Tongue and grooved for strong, convenient laying.
  - Can be used on joist centers up to 450mm apart.
  - Can be used as a platform floor.
  - Compatible with all floor coverings (tile, timber, carpet, vinyl, etc).
  - Can be used in wet areas provided boards are appropriately waterproofed (in accordance with AS 3740 or NCC Housing Provisions Part 10.2).
  - Can be used externally provided boards are fully waterproofed (in accordance with AS 4654 Part 1 & 2).
  - The boards must be stored, installed, finished and maintained in compliance with this guide and the relevant building standards, regulations and guidelines (eg: as contained in the National Construction Code (hereinafter NCC) and/or Building Code of Australia (hereinafter BCA)). If this is not done, it could negatively impact the boards' performance, contravene the national and/or local building codes / laws and even result in personal injury. Further, it will invalidate OxyMag's product warranty.

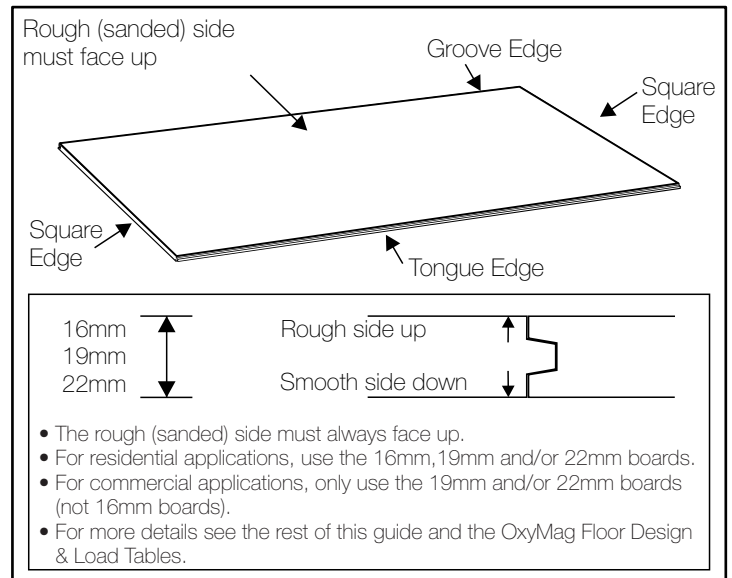

**FIGURE 1 - PRODUCT**

- b. This installation guide predicates that the individuals installing the OxyMag floor boards are suitably qualified, licensed, experienced tradesmen knowledgeable of Australian building standards, the NCC/BCA and well-practiced in the installation of substrate floor boards.
- c. Prior to commencing your installation of the OxyMag floor boards, ensure that you have the most current installation guide and technical information on hand. If you are unsure or require additional information, visit [www.oxyMag.com.au](http://www.oxyMag.com.au) or [www.itiAustralia.com.au](http://www.itiAustralia.com.au) or contact ITI at 02 8805 5000.

### The OxyMag floor boards come in the following sizes:

Part No.	Length mm	Width mm	Thickness mm	Weight kg		Units/Pack
				per m2	per Unit	
<b>OF2700X60016</b>	<b>2700</b>	<b>600</b>	<b>16</b>	<b>20.0</b>	<b>32</b>	<b>33</b>
<b>OF2700X60019</b>	<b>2700</b>	<b>600</b>	<b>19</b>	<b>23.7</b>	<b>38</b>	<b>28</b>
<b>OF2400X60022</b>	<b>2400</b>	<b>600</b>	<b>22</b>	<b>27.5</b>	<b>40</b>	<b>24</b>

### A2. RECOMMENDED TOOLS & ACCESSORIES

DESCRIPTION		APPROVED BRANDS
<b>a.</b>	<b>Nail:</b> 50 x 2.8mm; Galvanised / Corrosion-resistant nail; Fibre cement board is typical application	Paslode 50x2.8mm Fibre cement galvanised
<b>b.</b>	<b>Nail - D Head:</b> 50 x 2.87mm D Head gun nail; Galvanised / Corrosion-resistant	Paslode Impulse 50x2.87mm D Head
<b>c.</b>	<b>Nail - Ring Shank:</b> 50 x 2.87mm Ring Shank nail; Galvanised / Corrosion-resistant	Paslode Impulse Dekfast 50x2.87mm Ring
<b>d.</b>	<b>Screw for Timber Frames:</b> Class 3 minimum - 10g x 50mm self-drilling screw	<ul style="list-style-type: none"> <li>Blackhawk Speed Drive screws 10g x 50mm.</li> <li>Koala Deckfast screws 10g x 50mm.</li> <li>Simpson Strong-Tie decking screws DSDG50R250/1100 (12g) 5.5 x 50mm</li> <li>AnchorMark 5.5 x 50mm Decking Screws</li> </ul>
<b>e.</b>	<b>Screw for Steel Frames:</b> Class 3 minimum - Self-tapping wing-tipped 40mm screw	Buildex Wing Tek 10g 40mm
<b>f.</b>	<b>QuikDrive Collated Screw:</b> Various QuikDrive screws for fixing to timber or steel frames	Simpson Strong-Tie QuikDrive collated screws: <ul style="list-style-type: none"> <li>To Timber: WSCBGA158SA 8g x 42mm (Type 17)</li> <li>To Timber: DSDG50SA (12g) 5.5 x 50mm</li> <li>To Steel: CBSDGL158SA 10g x 42mm</li> </ul>

## A2. RECOMMENDED TOOLS & ACCESSORIES continued

DESCRIPTION	APPROVED BRANDS
<p><b>g- Construction Adhesive:</b> Use approved construction adhesive for gluing boards to timber or steel frames</p> <p><b>Joint Sealant:</b> Cartridge and / or sausage - Use approved joint sealant for sealing of all board joints (including all tongue and groove joints and butt joints).</p>	<p>Usable as adhesive and sealant:</p> <ul style="list-style-type: none"> <li>• HB Fuller: Toolbox Original; Fulaflex 650FC</li> <li>• Soudal: T-Rex Power Fast Grab; Multibond SMX35 / SMX50</li> <li>• Bostik: Seal 'n Flex</li> <li>• Sika: 11FC; Sikaflex-Pro</li> </ul>
<p><b>h. Temporary Weather Protection (Installer Responsibility):</b></p> <ul style="list-style-type: none"> <li>• OxyMag floor boards are not intended to be exposed to rain, ponded water, or uncontrolled moisture.</li> <li>• Temporary weather protection must be provided by the builder / installer immediately after installation and maintained until the boards are covered with an appropriate finish.</li> <li>• Boards must be fully waterproofed and/or covered with an appropriate finish within 90 days of installation.</li> <li>• A primer, epoxy, non-slip and/or similar coating does not constitute an appropriate finish.</li> </ul>	<p>N/A</p>
<p><b>i. Waterproofing:</b> OxyMag floor boards must be waterproofed as follows:</p> <ul style="list-style-type: none"> <li>• Internal wet areas: Waterproofed in accordance with AS 3740 or NCC Housing Provisions Part 10.2</li> <li>• External areas: Fully waterproofed in accordance with AS 4654 Part 1 &amp; 2</li> </ul> <p>We strongly advise builders/installers of OxyMag floor boards to use one of the approved brands in the adjacent column since the manufacturers of these brands have specified and endorsed their waterproofing products &amp; systems on the OxyMag floor boards. Should a non-approved waterproofing brand/s be used, the OxyMag product warranty will be invalidated. If there is a failure of the non-approved waterproofing on/relating to the OxyMag boards, the cost/burden of rectification will lie solely with the builder/installer.</p>	<ol style="list-style-type: none"> <li>1. Ardex / Dunlop Waterproofing System: <ul style="list-style-type: none"> <li>• No screed: Dunlop Damp Proof Membrane (one coat) + Dunlop Express Wet Area Waterproofing Membrane (2 coats) – See bottom of Section D2 for full specification</li> <li>• With screed: <ul style="list-style-type: none"> <li>· On OxyMag board: Dunlop Damp Proof Membrane</li> <li>· On screed: Dunlop Multipurpose Primer + Dunlop Express Wet Area Waterproofing Membrane</li> <li>· See bottom of Section D3 for full specification</li> </ul> </li> </ul> </li> <li>2. Gripset Waterproofing System: <ul style="list-style-type: none"> <li>· Primer: Gripset E60 Primer</li> <li>· Membrane options (dependent on application and as per Gripset specifications): Gripset BRW PF; Gripset XpressLay; Gripset 38 FC; Gripset Express Multi Pro; Gripset 2P</li> </ul> </li> <li>3. Duram Waterproofing System: <ul style="list-style-type: none"> <li>· Primer: Azcoseal</li> <li>· Membrane: Durabit Reo, Durabit EF, Multithane STD or HV</li> </ul> </li> </ol>
<p><b>j. Tiling Adhesive:</b> For securing tiles to OxyMag floor boards for internal dry areas only.</p>	<p>Ardex / Dunlop:</p> <ul style="list-style-type: none"> <li>• Primer: Dunlop Bond Coat (one coat must be applied prior to adhesive).</li> <li>• Adhesives: Dunlop Multipurpose Mastic, Dunlop Floor Tile Adhesive, Dunlop Universal Tile Adhesive, Dunlop Tiler's Mastic, Dunlop Trade Resaflex, Dunlop Wall &amp; Floor Tile Adhesive, Dunlop Tile-All.</li> </ul>
<p><b>k. Compressed Air, Gas or Battery Nail Guns:</b> For fixing sheets to timber or engineered timber frames</p>	
<p><b>l. Electric or Battery Powered Screw Driver:</b> For fixing boards to timber or steel frames</p>	
<p><b>m. Dust Extraction Circular Saw:</b> For cutting boards</p>	
<p><b>n. Saw Blade:</b> A poly-diamond or tungsten carbide blade for fast and clean cutting</p>	
<p><b>o. Dust Extractor Compatible with Circular Saw:</b> Required to remove dust from cutting - recommend HEPA filter</p>	
<p><b>p. Foam Backing Rod:</b> A 10mm diameter backing rod is to be fixed into all 5mm butt/control joints.</p>	
<p><b>q. Paint Scraper or Spatula:</b> For finishing joints and fixing heads when required</p>	

## B. GENERAL COMMENTS APPLICABLE TO INTERNAL & EXTERNAL APPLICATIONS

### B1. SCOPE

- This installation guide deals with the use of OxyMag floor boards in internal and external applications over appropriate timber and/or steel frames.

### B2. STORAGE

- OxyMag floor boards must be stored flat, dry, indoors, under-cover and raised from the ground at all times.
- The boards' edges and corners must be protected from damage and the weather (especially rain).
- The boards should be kept wrapped in their packs for the maximum time possible prior to being installed.

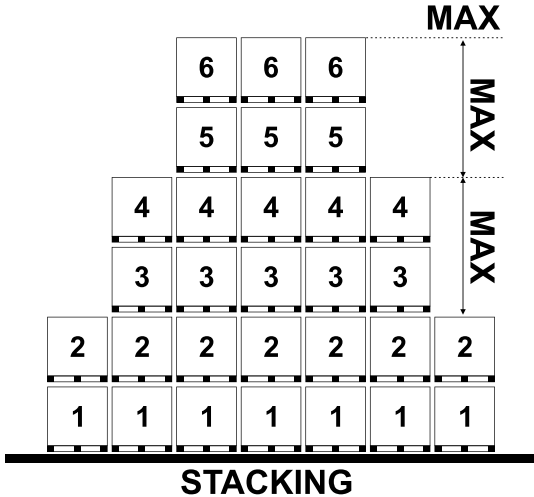

### B3. SAFE WORKING PRACTICES & HANDLING

- OxyMag floor boards do not present a health hazard whether intact or not. However, to ensure users' health and safety, the creation of dust must be minimised and personal protection must be assured at all times. Note the following:
  - Clean-up: Use industrial cleaner; Avoid dry sweeping.
  - Exposure controls:
    - In order to minimise exposure to dust, cut outdoors (do not cut indoors).
    - Position cutting station so that prevailing wind will blow away from user and other workers. If using circular saw, ensure that it is equipped with appropriate vacuum extraction.
  - Personal protection: As a minimum, when cutting, sanding, drilling or machining, wear the following:
    - A dust mask or appropriate respiratory equipment.
    - Safety goggles or a full-face shield.
    - Long-sleeved shirt and long trousers; Safety boots Safety gloves.
  - Always follow tool manufacturers' safety recommendations.
  - Refer to OxyMag's Safety Data Sheet (SDS) for more

### B4. DESIGN

#### B4.1. General

- It is essential that all design and construction complies with the relevant codes of the most current NCC/BCA as well as any other applicable national or local regulations.

#### B4.2. Responsibility

- It is the responsibility of the party in charge of the project or the specifier to see to it that the information provided in this guide is suitable for the planned use of the OxyMag floor boards and that any extra detailing is completed for a design or application that does not fall within this guide's scope. Further, as ITI does not specialise in waterproofing, it is the responsibility of the specifier to complete the required design and detailing to ensure that the waterproofing and finish comply with the specifications, guidelines and codes of the NCC/BCA and the manufacturer.

### B4.3. Loading

- OxyMag floor boards are designed to withstand various load categories in Table 3.1 of AS/NZS 1170.1 for imposed floor actions - refer to OxyMag Floor Boards Design & Load Tables. OxyMag's load capacities for maximum joist centres are reflected in the below table:

OxyMag Floor Board Thickness - mm	Maximum Joist Centres - mm	Concentrated Action Residential - kN*	Concentrated Action Commercial - kN**	Uniformly Distributed Action - kPa
16	450	1.8	N/A	3
19	450	1.8	2.7	4
22	600	1.8	2.7	4

\* = Residential concentrated actions are imposed on an area of 350mm<sup>2</sup>

\*\* = Commercial concentrated actions are imposed on an area of 0.01m<sup>2</sup> - only applicable to 19mm and 22mm boards (not 16mm boards)

### B5. FASTENERS

Fastener selection table is below:

Product	Timber Joist (min 45mm wide)	Timber I-Joist	LVL Solid Joist (only internal)	Steel Joist 0.75-1.6mm BMT	Steel Joist Between 1.6 & 1.9mm BMT
50 x 2.8mm FC nails	✓				
50 x 2.87mm D Head gun nails	✓	✓	✓		
50 x 2.87mm Ring Shank Nail	✓	✓	✓		
10g x 50mm self-drilling screw	✓	✓	✓		
Self-tapping wing-tipped 40mm Screw**				✓	✓
Various QuickDrive Screws***	✓	✓	✓	✓	✓

\* = A Class 3 finish is the minimum requirement of all fasteners.

\*\* = Consult manufacturer's specifications and ensure screws are appropriate for their intended application (including the joist thickness).

\*\*\* = Refer to Quick Drive's technical resources to identify the appropriate screws for the various joists.

- The above table is a guide only and the timber and steel manufacturers' recommendations must always be followed for fixing into various types of timber and steel joists. Fasteners must have the appropriate level of durability required for the intended project. This is of particular importance in coastal areas and areas subject to salt spray and other corrosive environments.
- Fasteners must be fully compatible with all other materials with which they are in contact to ensure the durability and integrity of the assembly.

### B6. FRAMING

- OxyMag floor boards are typically attached to timber or steel framing.
- The framing must be suitable for the application and comply with the relevant standards of the NCC/BCA – Specifically:
  - Timber framing must comply with AS 1684. Do not use unseasoned or wet timber.
  - Steel framing must comply with AS 3623.
- The framing must also comply with the manufacturer's specifications and installation instructions.
- The frame joists must be at least 45mm wide except for the following engineered joists:
  - I-joists must be at least 40mm wide and its flange depth must be sufficient to ensure fastener embedment.
  - LVL must be at least 42mm wide.
- The framing must be strong and durable.
- The boards' long edges must be laid across / perpendicular to the joists
- The boards' short edges (butt ends) must at all times be supported by a floor joist.
- Frame joists must be level and straight – ie: no more than 1mm deviation for every 1m in all directions.
- Floor space should be well ventilated.

### B7. BOARD LAYOUT AND SIDE UP

- Install boards' long tongue and groove edges across the floor joists and ensure the boards' short square edges (butt ends) are fully supported on joists.
- Depending on the application, the board layout may be in a staggered or squared pattern (see Figures 3 and 4 below).

- c. Always install the boards with the rough (sanded) side facing up.
- d. For residential applications, use the 16mm, 19mm and/or 22mm floor boards.
- e. For commercial applications, only use the 19mm and/or 22mm floor boards (not 16mm boards).

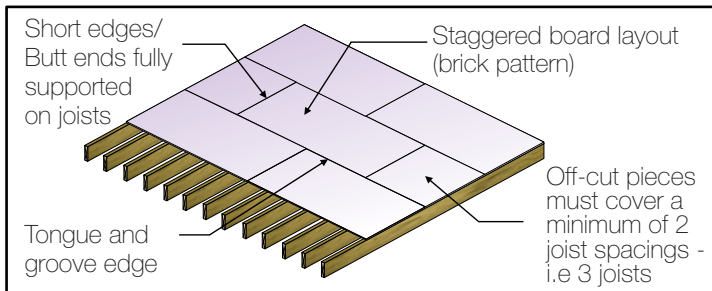

**FIGURE 3 - BOARD LAYOUT - STAGGERED PATTERN**

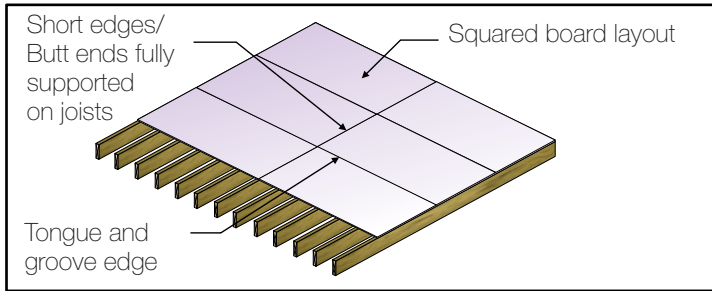

**FIGURE 4 - BOARD LAYOUT - SQUARED PATTERN**

- f. Table 3 below enables the specifier to select the appropriate board layout based on the floor/deck type and finish system:

Table 3 - Board Layout Selection			
Internal / External	Finish	Board Layout	Control Joints (indicative only)
Internal	Vinyl, Carpet, Timber, etc (not Tiled)	Staggered	Not required unless specified by engineer / specifier
Internal	Tiled dry & wet areas	Staggered	5.4m in direction of board
External	Waterproof system and tiling direct	Squared	2.7m in direction of board and 4.2m in direction of joists
External	Waterproof system, slip board, reinforced mortar bed and tile	Staggered	4.1m in direction of board

## B8. FINISHES

### B8.1. General

- a. It is imperative that:
  - all OxyMag floor boards are covered with an appropriate finish within 90 days of installation. An appropriate finish entails:
    - for all internal “wet” and/or external applications: The boards must be waterproofed and tiled. OR
    - for “dry” (not wet) internal applications: Any of the finishes detailed in B8.2. to B8.6.
- Important: A primer, epoxy, non-slip and/or any similar coating does not constitute an appropriate finish.**
- b. For all finishes over the OxyMag floor boards:
  - Make sure that every component of the finish system is completely compatible with each other and warranted for their planned use with OxyMag flooring.
  - The intended finish system must be installed in compliance with the manufacturer’s specifications and installation instructions.
- c. Boards must be clean and totally dry before applying the intended finish.
- d. Do not sand the OxyMag floor boards. Should the boards’ edges have slight height differences (not more than 3mm), level these out by applying an appropriate self-levelling product that is compatible with the intended floor finish.

- e. In relation to wet areas, it is essential that the installation complies with AS 3740 or NCC Housing Provisions Part 10.2, AS 3958 and any other relevant regulations.
- f. For approved waterproofing brands, refer to A2. Recommended Tools & Accessories, Page 3.
- g. For internal wet & external applications, the waterproofing & tiles must be applied within 90 days after installation.
- h. For internal applications, the final covering / finish must be applied within 90 days after installation.
- i. If any of the points in B8.1. and this installation guide are not followed, the product warranty will be invalidated.

### B8.2. Vinyl

- a. The installation of vinyl onto OxyMag floor boards is the same as for any other substrate floor board and requires no extra preparation.
- b. The end use for the area must be decided prior to works starting e.g. Internal dry area, Internal high traffic area, Internal wet area, etc.
- c. Consult with relevant vinyl manufacturers for the appropriate tested and warranted vinyl products as well as directions for their installation.

### B8.3. Carpet

- a. The surface of the OxyMag boards may require priming before applying adhesive.
- b. Underlays:
  - Most underlays can be spot fixed with staples, board pins or adhesive. Rubber, foam and synthetic underlays are usually loose laid and perimeter stapled.
  - Joints should be taped firmly together.
- c. Carpet may be fixed to OxyMag boards using perimeter stapling, tacking, or tackless systems, or adhesive installation systems.

### B8.4 Solid Timber Floorboards

- a. The installation of solid timber floorboards onto Oxy Mag floor boards is the same as for any other substrate floor board and requires no extra preparation, tools and/or materials.
- b. Use a full trowel of adhesive on the OxyMag boards as opposed to the “Z-type” pattern of adhesive.
- c. Secret nailing of the timber floorboards to OxyMag boards can be done with standard type staples and an air compressor type gun.
- d. Should top nailing be required, then a standard air compressor driven “T-nailer” can be used.

### B8.5 Floating Laminate Floorboards

- a. The installation of floating laminate floorboards onto Oxy Mag floor boards is the same as for any other substrate floor board and requires no extra preparation
- b. Follow manufacturer’s instructions.

### B8.6 Tiling

- a. In all cases, tiles must be installed in accordance with AS 3958, the NCC/BCA.
- b. Tiles can be laid either directly on the OxyMag floor boards or on sand-cement mortar bed over the boards (this applies to both wet and dry areas). For some applications, this mortar bed may need to be reinforced.
- c. Points to highlight:
  - i. The tiles must be laid from the control joint out and the tiles’ edges must extend over the butt joints by a minimum of 50mm.
  - ii. Always use a flexible adhesive that is suitable for the tile thickness and size
  - iii. Tilers must satisfy themselves that the maximum deflection of the boards is allowable/appropriate for the tiles being installed.
  - iv. For all other matters, consult with the tile manufacturer and/or the waterproofing supplier and/or the applicable tiling standards and regulations.

## B9. MAINTENANCE

- It is imperative that the OxyMag floor boards are stored in accordance with B2. above.
- Once installed, OxyMag floor boards must be protected at all times from weather exposure (especially rain) until an appropriate finish has been applied. Temporary protection is the responsibility of the builder / installer
- The OxyMag floor boards, if unprotected and/or uncovered, must never be exposed to water (eg: from gutters, 'hosing down', etc) & rain.
- The OxyMag boards' edges and joints must be protected whilst exposed to the weather - eg: we advise that adjacent joints be taped to avoid water ingress and damage.
- The boards must be kept dry and protected at all times. Ponded water must not be permitted to accumulate directly on the OxyMag Floor boards at any time. If it does happen, the ponded water must be eliminated immediately.
- Waterproofing must be maintained in accordance with AS 3740 or NCC Housing Provisions Part 10.2.

## C. INTERNAL & EXTERNAL INSTALLATION

### C1. GENERAL NOTES

- OxyMag floor boards incorporate an improved cement formulation with enhanced resistance to moisture-related degradation during normal installation periods. This does not remove the requirement for appropriate weather protection, waterproofing, and timely finishing as set out in this guide.
- OxyMag boards and framing must be in a dry and clean state prior to installation.
- The cementitious formulation of the OxyMag floor boards means that the smooth and rough (sanded) surfaces will be subject to colour variations and pinholes. These do not compromise the structural integrity of the boards and ITI will not deem these to be a valid reason for a return.

- Ensure that the boards' size and thickness are appropriate for the application prior to installation.
- Depending on the finish, the butt joints of the boards may require a gap. Consequently, a creep at the short end of the boards could happen and, over several boards, extra floor joists could be needed.
- The following applies re waterproofing of the OxyMag floor boards:
  - Internal wet areas: Waterproofing must be carried out in accordance with AS 3740 or NCC Housing Provisions Part 10.2, the NCC/BCA.
  - External areas: For all external applications, OxyMag boards must be fully waterproofed in compliance with AS 4654 Part 1 & 2. Refer to Section D of this guide for the waterproofing options.
  - The OxyMag floor boards must not be in direct contact with ponded water at any time. Accordingly, any damage, tear or water ingress in the waterproofing must be repaired immediately to prevent this happening.
- OxyMag floor boards are best cut with the smooth side facing down (rough side facing up) – ie: this achieves the sharpest edge cut.

### C2. INSTALLATION OF BOARDS

- The OxyMag floor boards must be installed with the rough (sanded) side facing up.
- The OxyMag floor boards must be installed at least 400mm above the ground.
- Figures 5 and 6 below show how to install the OxyMag floor boards in a staggered pattern. When installing the boards in a squared pattern the boards must be laid squared and aligned to each other and must not be offset. Prior to installation, determine board layout and control joint placement - see the board layout section B7.
- The following installation steps apply to both internal and external applications:

## INSTALLATION STEPS AND FASTENER LAYOUT

### STEP 1

Apply a continuous 6mm bead of approved construction adhesive to joists.

### STEP 2

Install Board 1 on the corner edge of the frame, across the joists, with the tongue edge on the perimeter frame and as per the fastener layout (fasteners to be fixed directly through the board into the framing).

#### Note:

The final row of fasteners adjacent to the long groove edge should be installed after the adjacent board/s have been slotted into Board 1's groove - See Step 6 below

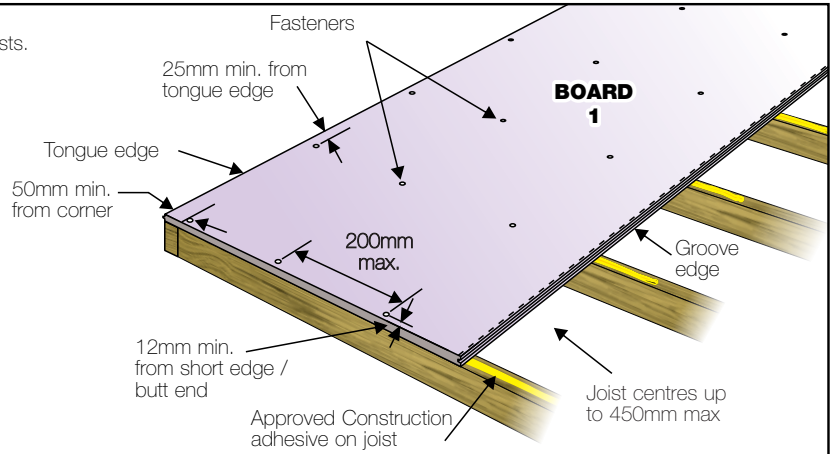

Fastener Distances Summary		
From Corner	Min.	50mm
Spacing along Joists	Max.	200mm
From Tongue/Groove Edge	Min.	25mm
From Short Edge/Butt End	Min.	12mm

FIGURE 5 – FIXING FIRST BOARD

### STEP 3

Fill the groove of Board 1 with an approved joint sealant

### STEP 4

Slot Board 2 (an off-cut / less than full-size board) into Board 1. Remove any excess sealant from the surface of the boards by using a spatula. Fasten Board 2 in place as per the fastener layout

**Note:** Avoid walking adjacent to or on the tongue & groove joints for at least 3 days after installation to allow the joint sealant to cure and bond.

### STEP 5

Slot Board 3 into Board 1. Butt joint Board 3 to Board 2 on the same joist. Fasten Board 3 with the same layout as Board 1 and Board 2

### STEP 6

Once each of Board 2 and Board 3 are in place, install the final row of fasteners adjacent to the long groove edge on Board 1. Ultimately there must be a minimum of 4 fasteners per board-width over all joists, including each individual board's butt ends

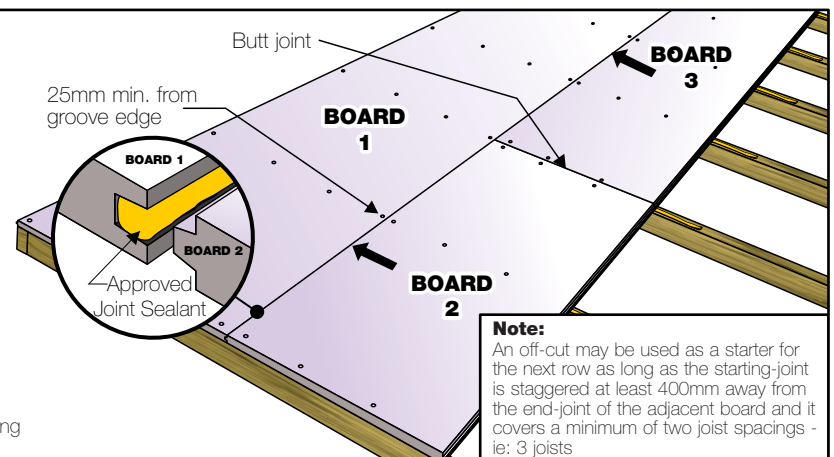

**Note:**  
An off-cut may be used as a starter for the next row as long as the starting-joint is staggered at least 400mm away from the end-joint of the adjacent board and it covers a minimum of two joist spacings - ie: 3 joists

FIGURE 6 – FIXING SECOND AND THIRD BOARDS

### C3. INSTALLATION OF BUTT JOINTS

a. The below table reflects the appropriate butt joints for the different applications:

TABLE 4 - Butt Joints		
Application	Gap between short edges / butt ends of adjoining boards	Description of butt joint
Internal - Dry	No gap	Adjoining boards are fixed flush to each other. No joint sealant is required
Internal - Wet	2mm	Gap is filled with joint sealant
External	5mm	A 10mm backing rod is placed into gap and must remain 5mm below surface of board. Remaining gap is filled with joint sealant

- b. For internal applications in wet areas and all external applications of the OxyMag floor boards, apply joint sealant over:
- all board joints – ensure that an unbroken seal has been formed; and
  - the heads of fasteners (which must be fixed flush to the board prior to sealing)
- c. To give the sealant an opportunity to set and dry out, walking, running etc. on the floor should be avoided for 24-48 hours. Until the final finish has been applied, the boards' surface should be protected from any damage.
- d. The following installation steps relate to butt joints in External applications. The drawing reflects the boards in a squared pattern but applies equally to the boards in a staggered pattern.

### BUTT JOINT FOR EXTERNAL APPLICATIONS

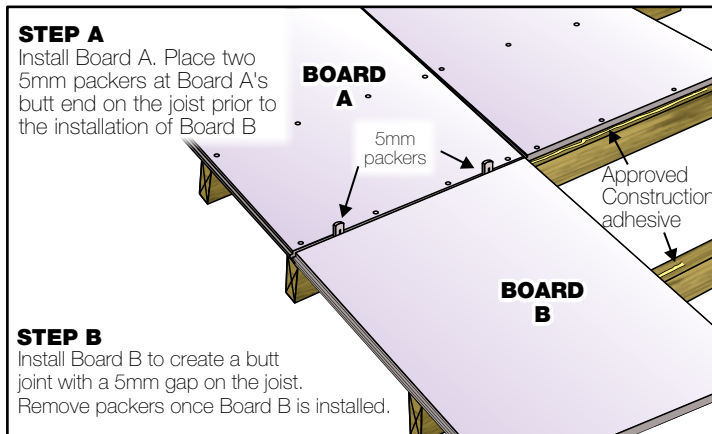

FIGURE 7 - CREATING 5MM BUTT JOINT

### C4. CONTROL JOINTS - Tiled areas only

- a. Control joints in the floor boards and extending through the tiles (see Figure 9 below for an example of an internal control joint) are to be provided in the below applications as follows (unless compelled to do otherwise by the NCC/BCA and / or local regulations):
- Internal dry and wet areas: Every 5.4m in direction of boards – See Figure 8 below.
  - External with waterproof system and tiling direct: Every 2.7m in direction of boards and 4.2m in direction of joists – See section D2.
  - External with waterproof system, slip board, reinforced mortar bed and tile: Every 4.1m in direction of boards – See section D3.
- b. In addition, include control joints:
- Where the direction of the floor changes (for example, an L shaped room)
  - At entrances to a room where the tiled surface continues into the adjacent room
  - Where existing structural joints are located.

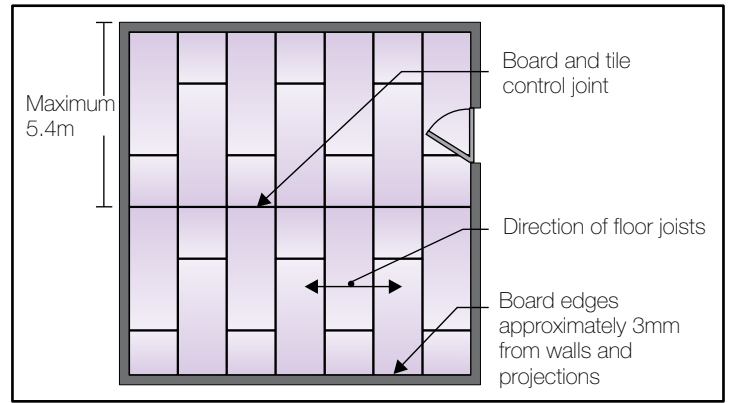

FIGURE 8 - BOARD CONTROL JOINT LAYOUT

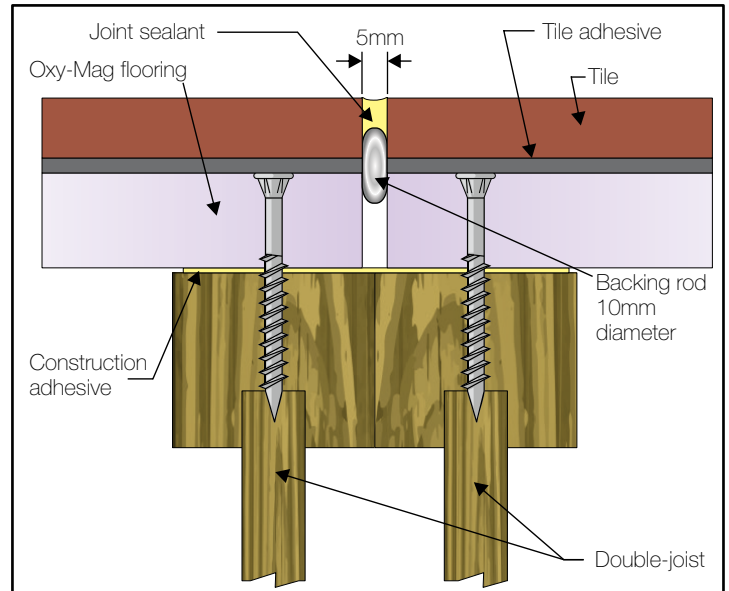

FIGURE 9 - CONTROL JOINTS: INTERNAL BOARD AND TILE JOINT

### Note the following:

- Additional control joints may be required in both directions depending on the specific application and the board layout. Accordingly, refer to AS 3958 for more conclusive, detailed guidance.
- Control joints are typically not required in floors which do not have a tiled finish unless they have been specified by the engineer or specifier.
- The above advice on control joints is purely indicative. The frequency of control joints is dependent on many factors (eg: type of joists, joists spacing, climatic conditions, prevalence of air conditioning, etc) and is ultimately the decision of the responsible engineer, specifier and/or builder of the site.

### C5: EXTERNAL INSTALLATION - FURTHER CONSIDERATIONS

- a. The builder / project responsible person must ensure that:
- The step down from the internal FFL level to the deck's finished surface meets the minimum requirements of the NCC/BCA.
  - The minimum fall in the deck from the building to the outside edge is 1:100.
  - The decking must not have sumps for drainage.
  - The upright supports of a balustrade must be fixed to the structural frame - ie: they may not be fixed to the OxyMag floor boards and must not damage the deck's waterproofing.

## D. WATERPROOFING - EXTERNAL APPLICATIONS

### D1. WATERPROOFING SYSTEMS

- a. OxyMag floor boards may be installed externally (eg: as a deck) over durable timber or corrosion resistant light gauge steel frames under the following conditions:
  - i. OxyMag floor boards are installed using a staggered pattern (as reflected in Figure 3 above) or a squared pattern (as reflected in Figure 4 above).
  - ii. OxyMag floor boards and resultant decks are made fully waterproof (ie: not only water-resistant) in accordance with AS 4654 Part 1 & 2. Waterproof decks will have either:
    - 1: liquid applied membranes - See section D2; or
    - 2: a flexible board membrane and mortar bed - See section D3.
  - iii. The entire waterproofing system is purchased from and installed by the same manufacturer/supplier and all components are fully compatible with one another.
  - iv. Recommended waterproofing brands can be found in the table at A2. Recommended Tools & Accessories of this guide.
  - v. The installation of the OxyMag floor boards is in compliance with all aspects of this installation guide.

### D2. WATERPROOF SYSTEM 1: LIQUID MEMBRANE METHOD

- a. Basic description and requirements:
  - i. Constitutes the application of an appropriate and approved waterproof liquid membrane system onto the OxyMag floor boards with tiles laid directly to the membrane with compatible adhesive.
  - ii. Floor boards have a squared layout.
  - iii. A licensed applicator who is able to provide a waterproofing guarantee for tiling direct must install the selected membrane system and its components.
  - iv. Recommended control joints are 2.7m in the direction of the boards and 4.2m in the direction of the joists.
  - v. The tiler and builder must ensure that all board control joints extend from the joist up through the tiles and that tile control joint spacings adhere to the relevant tile codes.

## E. PRODUCT INFORMATION, WARRANTY & DISCLAIMER

### E1. PRODUCT INFORMATION

- a. OxyMag flooring is an advanced reinforced cement composite board.
- b. For Design & Load Tables, Summary of Physical Properties and/or a Safety Data Sheet (SDS) in regards to OxyMag floor boards, visit [www.oxythag.com.au](http://www.oxythag.com.au) or ask ITI on 02 8805 5000.

### E2. PRODUCT WARRANTY

- a. OxyMag boards have a 10 year product warranty. The OxyMag floor boards must be stored, installed, finished and maintained in accordance with this installation guide. If this is not done, it will invalidate OxyMag's product warranty. For terms and conditions of the product warranty refer to [www.oxythag.com.au](http://www.oxythag.com.au) or ask ITI on 02 8805 5000.

### E3. DISCLAIMER

- a. This installation guide is intended to assist installers to properly install OxyMag floor boards. In regard to the design of the project for which OxyMag floor boards are to be used, this installation guide is not a substitute for professional engineering and design consultation. At all times the installer must consult and follow:
  - i. Relevant building codes and specifications including the NCC/BCA.
  - ii. All tool and materials manufacturers' instructions.
- b. Any installation not in compliance with this installation guide will invalidate the product warranty.
- c. The information contained in this guide is subject to change by ITI without prior notice.
- d. This installation guide is published and distributed on the basis that ITI is not responsible for the results of any actions taken by installers, builders and users based on information contained in this guide and/or based on any error or omission in this guide. ITI does not accept any responsibility whatsoever for any misrepresentation made by any person of the information contained in this guide and expressly disclaims all and any liability and responsibility to any person, whether a user or reader of this guide or not, in respect of claims, losses or damage or any other matter, either direct or consequential arising out of or in relation to the use and reliance, whether wholly or partially, upon any information contained or products referred to in this guide.

- b. The tiler and builder must ensure compliance with the NCC/BCA and all relevant standards / codes.
- c. Ardex Waterproofing Specification (no screed):
  - i. The recommendation is 1 coat of Dunlop Damp Proof Membrane followed by 2 coats of Dunlop Express Wet Area waterproofing membrane. Tiling can commence after the waterproofing membrane has cured as indicated in the product data sheets.

### D3. WATERPROOF SYSTEM 2: SLIP PANEL AND REINFORCED MORTAR BED

- a. Basic description and requirements:
  - i. Constitutes the application of the following onto the OxyMag floor boards (in order):
    - Waterproof membrane system;
    - Slip panel;
    - Reinforced mortar bed – recommend the following:
      - depth is 50mm;
      - control joints every 4.5m x 4.5m in mortar bed.
    - Another waterproof membrane system (recommended);
    - Tiles.
  - ii. Floor boards have a staggered layout.
  - iii. Represents the minimum requirement over a living space / habitable room
  - iv. Recommended control joints in OxyMag floor boards are 4.1m in the direction of the boards.
  - v. The tiler and builder must ensure that all mortar and/or board control joints and their spacings comply with the NCC/BCA and all relevant standards / codes.
- b. Ardex Waterproofing Specification (with screed):
  - i. If falls are not built into the structure, a self-supporting screed must be installed to create falls to waste (1:60 to 1:80 or 1:100 for external). The board surface is first sealed using Dunlop Damp Proof Membrane before a 0.2mm thick slip sheet and a minimum 40mm self-supporting screed is installed. The screed is then waterproofed using Dunlop